



# WIRING HARNESS FOR InSight Scanner 61-6944-XXX 61-6944-XXXR

## USING FIREYE WIRING HARNESS

To provide an easy method to wire the InSight Scanners in a “Multi-drop” wiring configuration for remote communications, Fireye offers a wiring harness in several different lengths. The harness has a pre-wired female quick disconnect to plug into the male quick disconnect on the scanner. The female quick disconnect is available in straight or 90°, right-angle styles. The other end of the wiring harness has a conduit box with a 16 pole terminal strip.

The terminal strip uses push-type cage clamp connectors. Use a small screwdriver or similar device to depress the slot beside the connector to open the connector and then insert the wire. Remove the screwdriver to secure the wire. The connector will accept 28 to 12-gauge wire\*. The terminal strip should be wired in the following manner:

Cable	Color	InSight Model 95 Function	Wiring Harness	Wire cable to:
59-497 Cable	Black/Red	Power (+) 24 VDC	1	To Control Room (Burner Management System)
	White/Blue	Power (-) 24 VDC	2	
	White /Black	Flame Relay (N.O.)	3	
	White/Red	Flame Relay (N.O.)	4	
	Red	Fault Relay (N.C.)	5	
	Pink	Fault Relay (N.C.)	6	
	Violet	4-20 mA (+)	7	
	Grey/Red	4-20 mA (-)	8	
	Blue/Red	File Select 1	9	
	Yellow	File Select 2	10	
	Brown	Communications A	11	
	Orange	Communications B	12	
Belden 8761	Black	RS485 COM A	11	To next flame scanner
	Clear	RS485 COM B	12	
Belden 8761	Black	RS485 COM A	11	To previous flame scanner (or IC485 converter)
	Clear	RS485 COM B	12	

SEE WIRING DIAGRAM ON PAGE 4.

\*18 gauge or larger should be used for power and relay contacts.

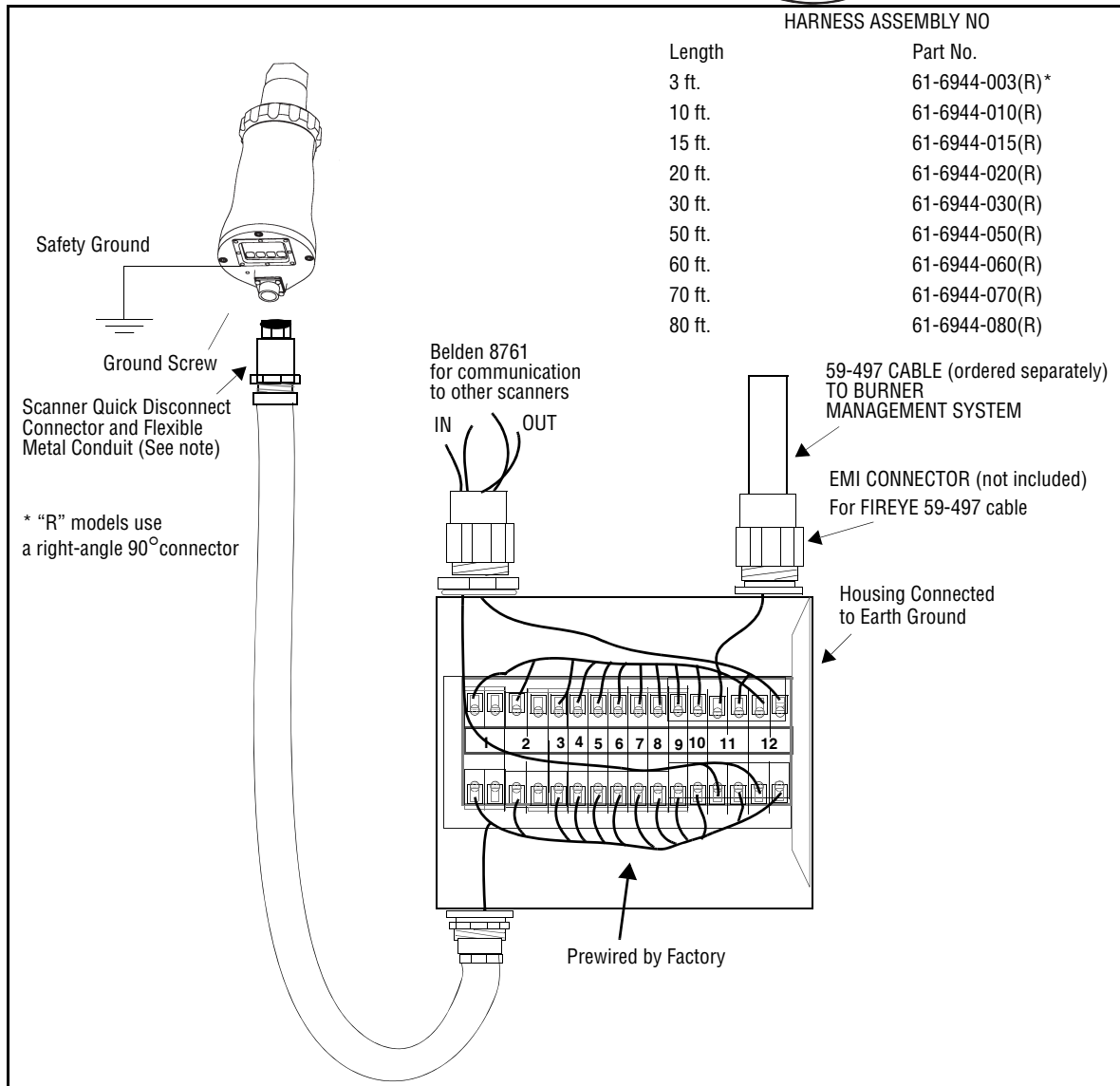

## GROUNDING AND SHIELDING TECHNIQUES

FOR USE ON SCANNERS OR SCANNER CABLE LOCATED WITHIN 12" OF A HIGH ENERGY OR HIGH VOLTAGE SOURCE.

1. Connect a safety ground to scanner housing, per applicable local codes and regulations.
2. The scanner and scanner cable (preferably within flexible conduit) MUST be located at least 12" from the ignition source.
3. Run a ground wire from the ignition transformer chassis to the ignitor assembly.
4. Replace all frayed, cracked, or dirty (oily) ignition wire. Ignition wire must be in good working condition.
5. Electrically isolate the scanner from the burner using a heat insulating nipple provided with the surface mounting flange.
6. Cooling/Purge Air must be electrically isolated from the scanner (e.g. isolated short rubber hose).

**Note: Class 1 Division II Hazardous Area requirements for InSight scanners with electrical connectors (non-CG models):**

1. It is necessary to either use the "C" or "RC" model cable assemblies or cable connector kits and install the cable in flexible conduit, or use the 61-6944 Wiring Harness.
2. The connector coupling nut setscrew must be tightened after mating the cable to the scanner.
3. The red warning label must be adhered to the connector housing.

## SUGGESTED WIRING FOR INSIGHT MODEL 95 COMMUNICATIONS

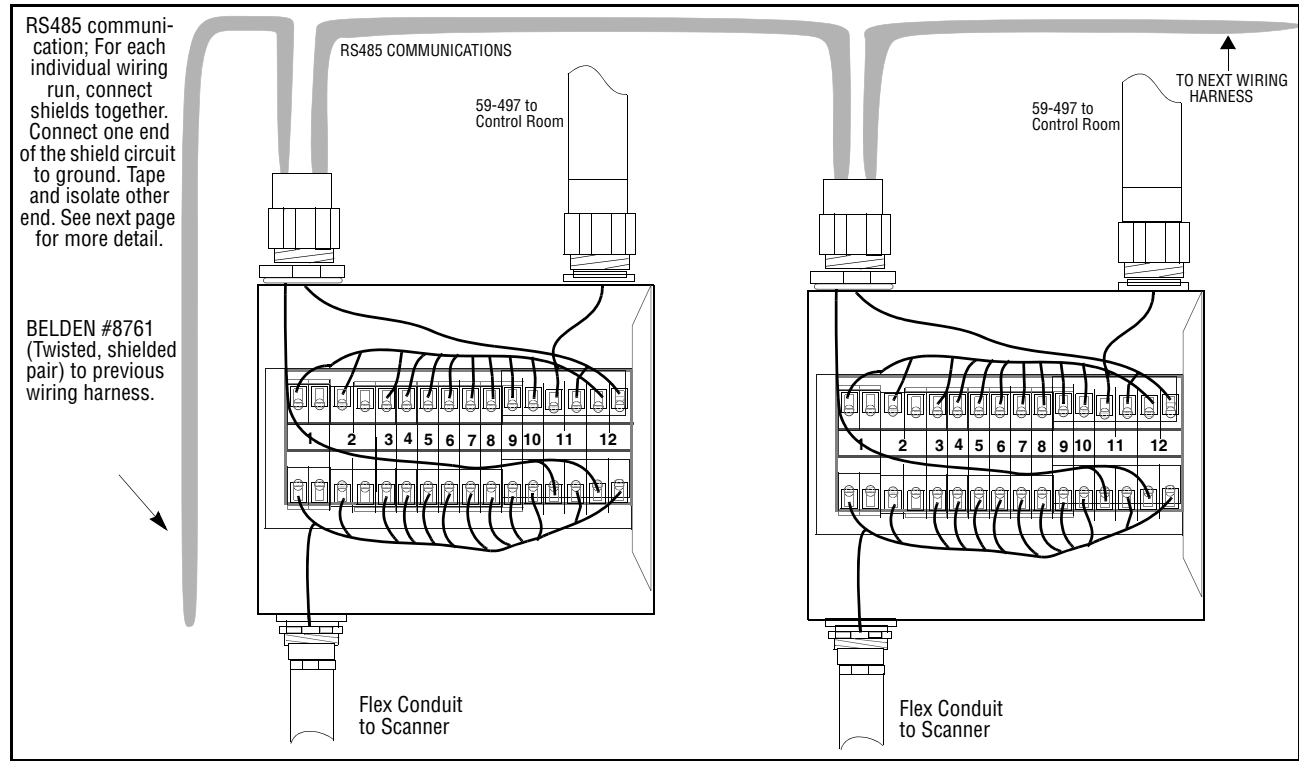

## WIRING DIAGRAM FOR WIRING HARNESS

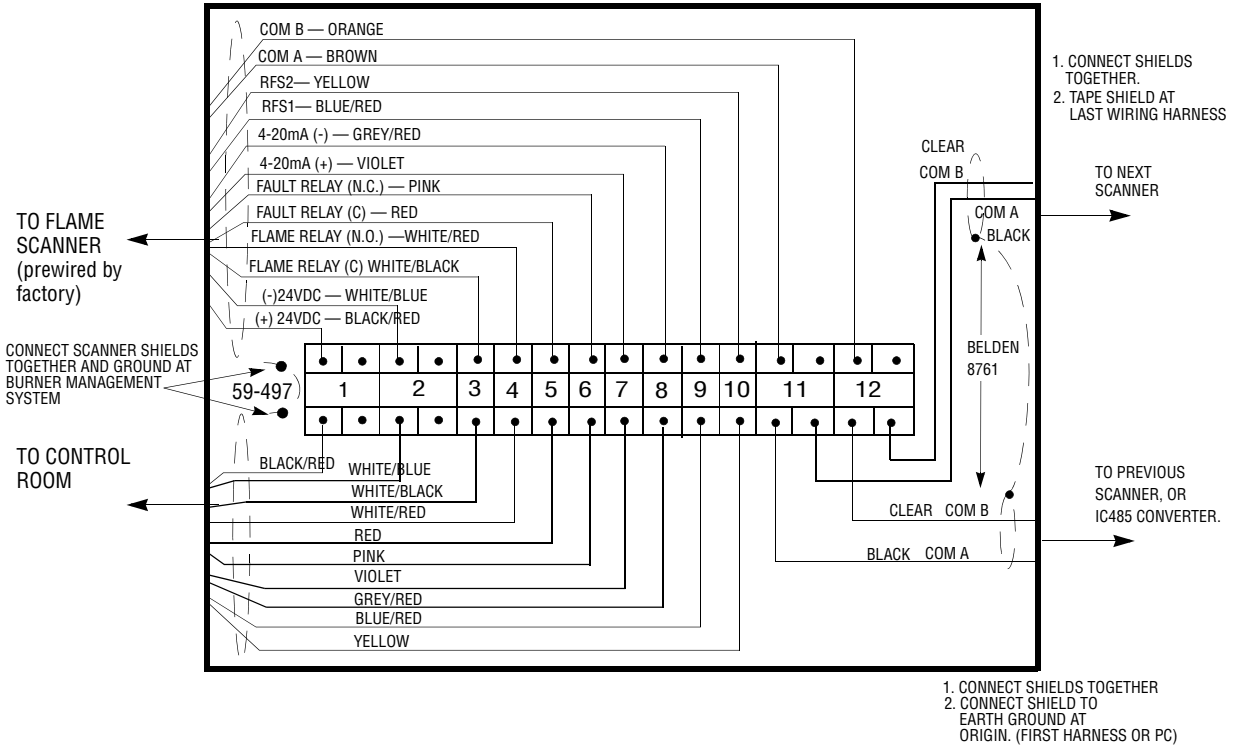



## MOUNTING DIMENSIONS

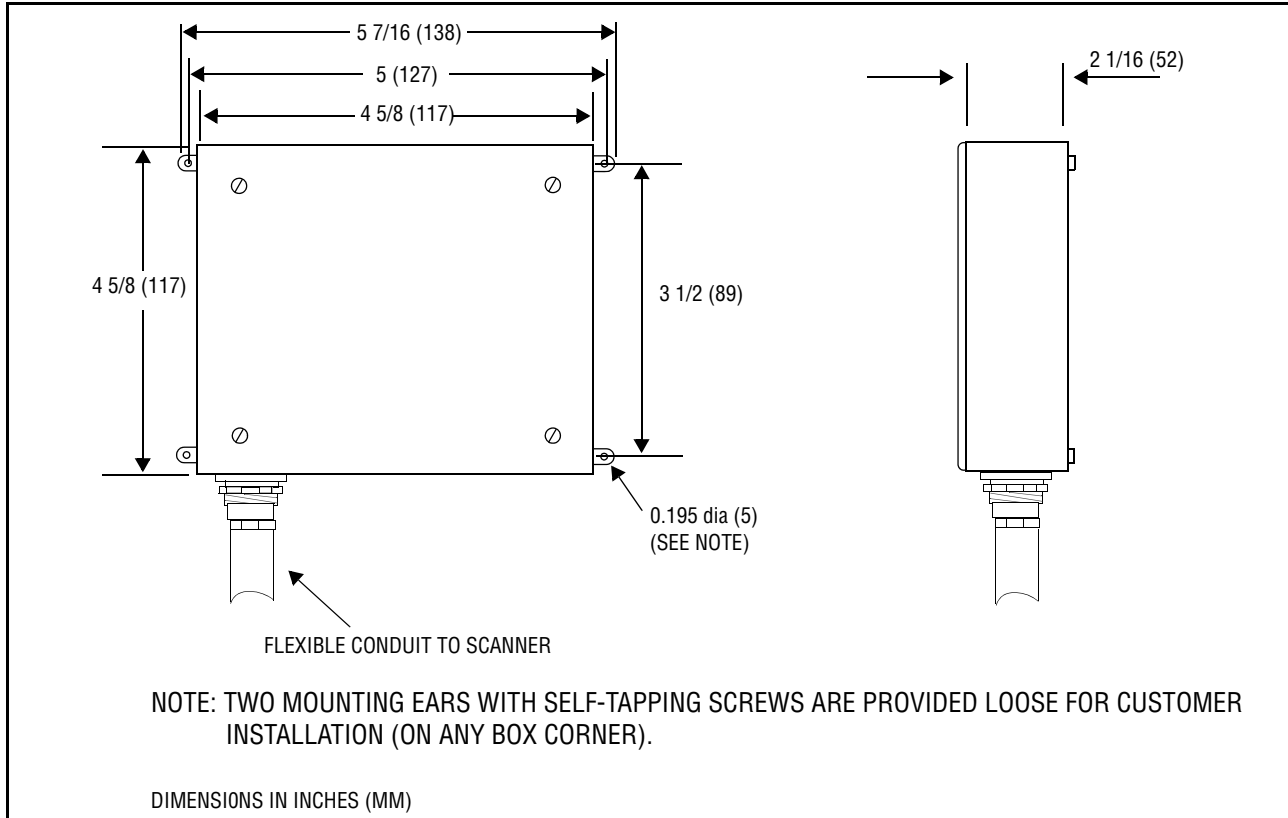

## NOTICE

When Fireeye products are combined with equipment manufactured by others and/or integrated into systems designed or manufactured by others, the Fireeye warranty, as stated in its General Terms and Conditions of Sale, pertains only to the Fireeye products and not to any other equipment or to the combined system or its overall performance.

## WARRANTIES

FIREEYE guarantees for *one year from the date of installation or 18 months from date of manufacture* of its products to replace, or, at its option, to repair any product or part thereof (except lamps, electronic tubes and photocells) which is found defective in material or workmanship or which otherwise fails to conform to the description of the product on the face of its sales order. **THE FOREGOING IS IN LIEU OF ALL OTHER WARRANTIES AND FIREEYE MAKES NO WARRANTY OF MERCHANTABILITY OR ANY OTHER WARRANTY, EXPRESS OR IMPLIED.** Except as specifically stated in these general terms and conditions of sale, remedies with respect to any product or part number manufactured or sold by Fireeye shall be limited exclusively to the right to replacement or repair as above provided. In no event shall Fireeye be liable for consequential or special damages of any nature that may arise in connection with such product or part.



FIREEYE®  
3 Manchester Road  
Derry, New Hampshire 03038 USA  
www.fireeye.com

CU-97  
APRIL 8, 2013  
Supersedes March 21, 2007